

SINGLE CRYSTAL FIBER AMPLIFIER

τΑranis

Single Crystal Fiber (SCF) amplifiers are the best solution to amplify short pulse lasers in a MOPA configuration since they do not suffer from the strongly aberrant thermal lensing effect that degrades the beam in bulk crystal amplifiers. Fibercryst pioneered the SCF technology and developed the τΑranis module benefiting from a unique, patented, cooling solution for high power pumping. τΑranis module is an industrial component with no adjustments; the only requirements are proper alignment and focusing of the seed laser. A τΑranis module can amplify a pulsed seed laser from a few kHz to several tens of MHz, or a seed laser from ten's of nanoseconds down to a few hundred of femtoseconds with seed powers ranging from a few hundred of mWatts up to tens of Watts.



τΑranis modules are available with Yb:YAG (Ytterbium) or Nd:YAG (Neodymium) material.

Nd:YAG water cooled module NDYG-PL0002-W2N

Crystal dimension:

- Length : 50 +/- 1 mm
- Typical Diameter : 1 mm +/- 5%
- Typical doping rate : 0,2 % at.

Water-cooled system:

- Typical heat transfer coefficient
fiber/metallic plate $H=5W/cm^2.K$
- Dimensioned for up to 200 W pumping
- Copper water box with protective Ni layer

Water cooling should be operated under 5 bars of pressure and between 3 to 4 l/min at 18°C

Operating temperature: +15°C to +35°C (no condensing water)

Storage temperature: +15°C to +35°C (no condensing water)

1 – DIMENSIONS

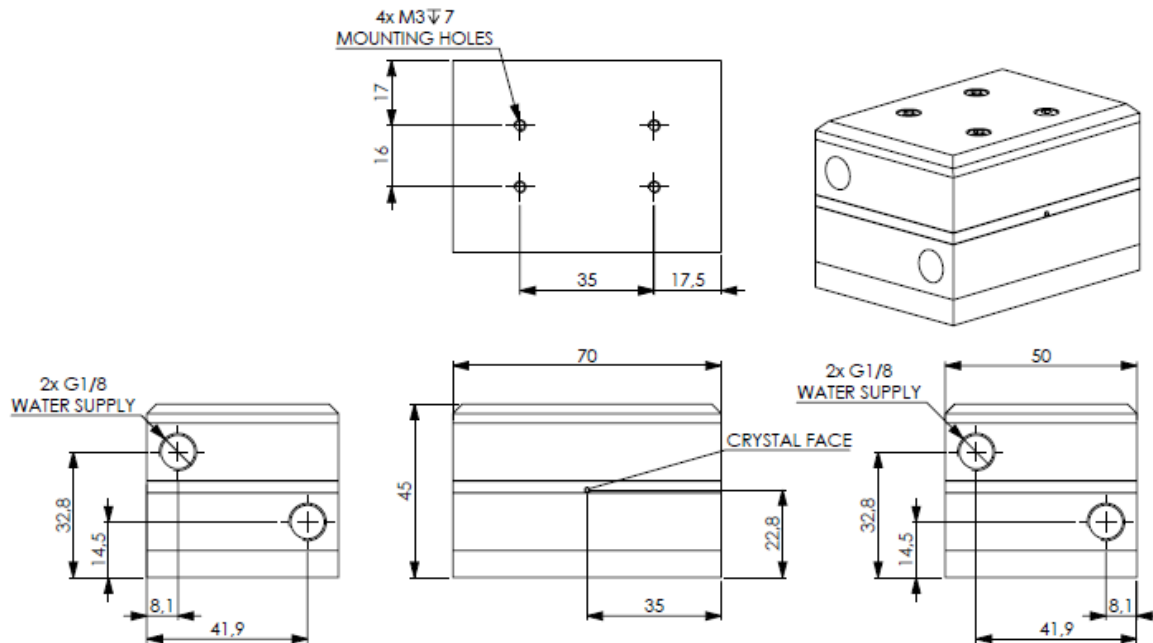

2 – OPTICAL SPECIFICATIONS

- Typical transmission: >98% at 1 μm (see note 1 and note 4)
- Depolarization losses: < 2% (see note 1)
- Guiding efficiency: > 80% at 1 μm (see note 1)
- Coating: AR/AR 808 nm and 1064 nm.
- Clear aperture diameter: 800 μm
- Max energy density: 3 J/cm² at 1 ns pulse duration
- Pump wavelength: 808 nm
- Max pump power: 150 W (see note 2)
- Max input pulse duration: Continuous wave
- Min output pulse duration: 10 ps (see note 3)

- (1) Experimental conditions upon request. The transmission value takes into account the reabsorption effect at 1 μm without pumping.
- (2) Above 150 W of pump power, contact FIBERCRYST for specific recon
- (3) Below 10ps pulse duration, contact Fibercryst.
- (4) For optimum performances the center wavelength should be at 1064.3 nm + or – 0,1 nm and the full width at half maximum (FWHM) lower than 1 nm.

The TORONIS module should be handled with cares as any other optical component.